

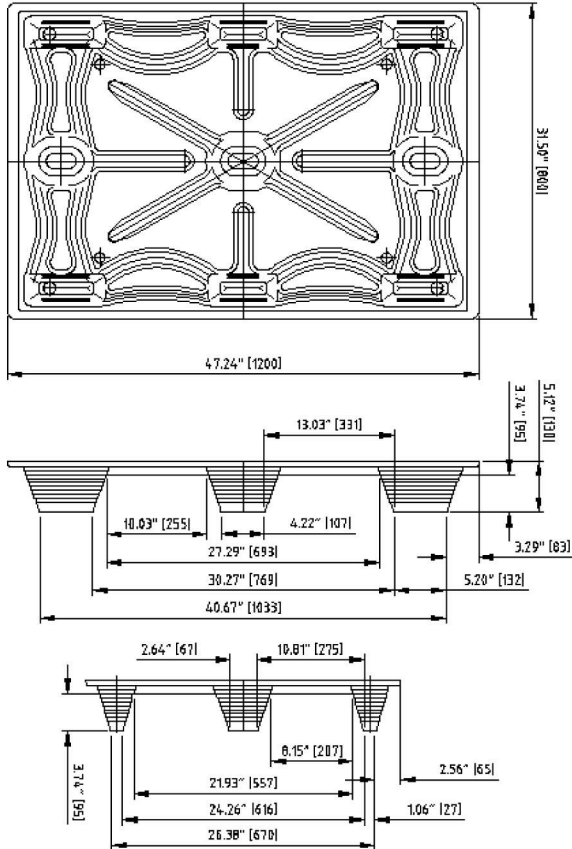

TECHNICAL DATA SHEET

1200.00 mm x 800.00 mm (47.24" x 31.5")

PRESSWOOD PALLET



1200mm x 800mm (47.24" x 31.5") PRESSWOOD PALLET

* RIBBING DESIGN ON THE PALLET DECK MAY DIFFER FROM THAT SHOWN

All dimensions in inches

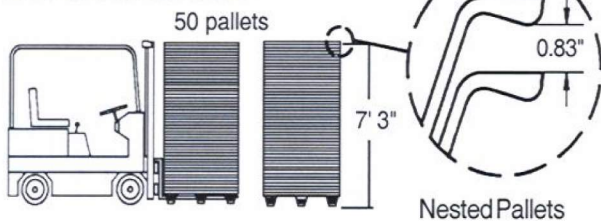

Nested Pallets

Manufactured according to the **werzalit** process.

Manufacturing & Composition

Inca Pallets are molded in one solid piece from dried wood fibers and environmentally safe synthetic resin in a compression mold under high pressure and temperature.

Low Moisture Content

Only 6 - 8% moisture content, no moisture transmission to product or packaging load on the pallet.

Approximate Surface Area

Top Deck: 765 sq. inches
Footprint: 76 sq. inches

Approximate Dynamic Load Capacity*

WEIGHT	CAPACITY	COLOR CODE	PAINTED STRIPE
Ex Heavy	2500 lbs.		White

*Load uniformly distributed on pallet deck. Actual load capacity is application specific & dependant upon the product, packaging, load containment & handling environment. The testing of Inca pallets with the intended application is strongly recommended.

4 Way & 2 Way Entry

4-way entry with lift truck. 2-way entry with pallet jack.

Nestability

A stack of 50 Inca Pallets nest approximately 7' high. For each additional pallet, add 2" to height of stack.

Rounded Corners & Tapered Legs

Pallets have all rounded corners and tapered legs which make them ideal for stretch or shrink wrapping.

Design for Safety

Because Inca Pallets weigh up to 50% less than conventional hardwood pallets, they are safer and easier to handle. And, there are no nails or splinters to damage product or injure personnel.

Full Truckload Capacity

Quantities vary with pallet size and weight per truckload, typically:

WEIGHT	TRUCKLOAD	LBS./PALLET
Ex-Heavy	1,500	26 (+/- 1.5)

Export Approved!

Save money, time & costly delays. Inca presswood pallets are welcome worldwide. They are considered "processed wood" per ISPM 15 export wooden packaging regulations. No extra, costly treatment against infestation is required!



LITCO INTERNATIONAL INC.

Molded Products Group | P.O. BOX 150, ONE LITCO DR., VIENNA, OH 44473

Fax 330-539-5388 | info@litco.com

Phone 330-539-5433 | www.litco.com

6/8/16

